

REXCON[®] PLANT PARTS CATALOG 2026

Offering quality replacement parts for RexCon batch plants & mixers



Where to Order

To place an order for parts, contact your nearest dealer. A list of all locations and phone numbers, sorted alphabetically, is provided below.

RexCon® Dealer Locator (Listed by State)					
Phone number for Sales Department: 262.539.4550					
State	Distributor / Email Address	Address / Website	City, State	ZIP Code	Phone
Alabama	Southern Concrete Machinery, LLC chris@southernconcretemachinery.com	PO Box 11098 www.SouthernConcreteMachinery.com	Murfreesboro, TN	37129	833-4CON-ECO 615.957.4600 - Cell
	Alaska	CONAGSCO parts@conagsco.com	P.O. Box 225 www.conagsco.com	Harrington, WA 98134	800.326.1950 800.326.1950 - Fax
Arizona	Dave Humphrey Enterprises, Inc. sales@dhenoble.com	145 Gandy Dancer Drive www.dhenoble.com	Tracy, CA	95377	800.434.3462 209.835.4222 - Fax
	Arkansas	Southern Concrete Machinery, LLC chris@southernconcretemachinery.com	PO Box 11098 www.SouthernConcreteMachinery.com	Murfreesboro, TN 37129	833-4CON-ECO 615.957.4600 - Cell
California	Dave Humphrey Enterprises, Inc. sales@dhenoble.com	145 Gandy Dancer Drive www.dhenoble.com	Tracy, CA	95377	800.434.3462 209.835.4222 - Fax
	Colorado	Faris Machinery Company dmansheim@farismachinery.com	5770 East 77th Avenue www.farismachinery.com	Commerce City, CO 80022	800.551.7768 303.287.9273 - Fax
Connecticut	Mid Atlantic Concrete Equipment parts@maconcrete.com	P.O. Box 36 www.maconcrete.com	Lititz, PA	17521	888.378.6237 888.378.6223 - Fax
	Delaware	Mid Atlantic Concrete Equipment parts@maconcrete.com	P.O. Box 36 www.maconcrete.com	Lititz, PA 17521	888.378.6237 888.378.6223 - Fax
Florida	Concrete Equipment Supply, LLC Jhanson@concreteequipmentsupply.com	PO Box 7 8700 Traid Dr www.concreteequipmentsupply.com	Colfax, NC	27235	800.680.5604 704.360.2673 - Fax
	Georgia	Concrete Equipment Supply, LLC Jhanson@concreteequipmentsupply.com	PO Box 7 8700 Traid Dr www.concreteequipmentsupply.com	Colfax, NC 27235	800.680.5604 704.360.2673 - Fax
Hawaii	Dave Humphrey Enterprises, Inc. sales@dhenoble.com	145 Gandy Dancer Drive www.dhenoble.com	Tracy, CA	95377	800.434.3462 209.835.4222 - Fax
	Idaho	CONAGSCO parts@conagsco.com	P.O. Box 225 www.conagsco.com	Harrington, WA 98134	800.326.1950 800.326.1950 - Fax
Illinois - Northern	Concrete Machinery Company, LLC chris@concretemachinery.co	PO Box 10348	Murfreesboro TN	37129	319.505.3526
	Illinois - Southern	Surma Equipment Sales chris@surmaequipment.com	10207 NW 72nd Terrace www.surmaequipment.com	Weatherby Lake, MO 64152	833.368.1329 913.927.1262 - Cell
Indiana	Concrete Machinery Company, LLC chris@concretemachinery.co	PO Box 10348	Murfreesboro TN	37129	319.505.3526
	Iowa	Advanced Technical Services, Inc. parts@ats-inc.net	702 LeClair Street www.ats-inc.net	Cedar Falls, IA 50613	888.296.7278

RexCon® Dealer Locator (Listed by State)

Phone number for Sales Department: 262.539.4550

State	Distributor / Email Address	Address / Website	City, State	ZIP Code	Phone
Kansas	Surma Equipment Sales	10207 NW 72nd Terrace	Weatherby Lake, MO	64152	833.368.1329
	chris@surmaequipment.com	www.surmaequipment.com			913.927.1262 - Cell
Kentucky	Southern Concrete Machinery, LLC	PO Box 11098	Murfreesboro, TN	37129	833-4CON-ECO
	chris@southernconcretemachinery.com	www.SouthernConcreteMachinery.com			615.957.4600 - Cell
Louisiana	Astec RexCon				262.539.4550
	parts.burlington@astecindustries.com	www.astecindustries.com			
Maine	Mid Atlantic Concrete Equipment	P.O. Box 36	Lititz, PA	17521	888.378.6237
	parts@maconcrete.com	www.maconcrete.com			888.378.6223 - Fax
Maryland	Mid Atlantic Concrete Equipment	P.O. Box 36	Lititz, PA	17521	888.378.6237
	parts@maconcrete.com	www.maconcrete.com			888.378.6223 - Fax
Massachusetts	Mid Atlantic Concrete Equipment	P.O. Box 36	Lititz, PA	17521	888.378.6237
	parts@maconcrete.com	www.maconcrete.com			888.378.6223 - Fax
Michigan	Concrete Machinery Company, LLC	PO Box 10348	Murfreesboro TN	37129	319.505.3526
	chris@concretemachinery.co				
Minnesota	Advanced Technical Services, Inc.	702 LeClair Street	Cedar Falls, IA	50613	888.296.7278
	parts@ats-inc.net	www.ats-inc.net			
Mississippi	Southern Concrete Machinery, LLC	PO Box 11098	Murfreesboro, TN	37129	833-4CON-ECO
	chris@southernconcretemachinery.com	www.SouthernConcreteMachinery.com			615.957.4600 - Cell
Missouri	Surma Equipment Sales	10207 NW 72nd Terrace	Weatherby Lake, MO	64152	833.368.1329
	chris@surmaequipment.com	www.surmaequipment.com			913.927.1262 - Cell
Montana	Faris Machinery Company	5770 East 77th Avenue	Commerce City, CO	80022	800.551.7768
	dmansheim@farismachinery.com	www.farismachinery.com			303.287.9273 - Fax
Nebraska	Advanced Technical Services, Inc.	702 LeClair Street	Cedar Falls, IA	50613	888.296.7278
	parts@ats-inc.net	www.ats-inc.net			
Nevada	Dave Humphrey Enterprises, Inc.	145 Gandy Dancer Drive	Tracy, CA	95377	800.434.3462
	sales@dhenoble.com	www.dhenoble.com			209.835.4222 - Fax
New Hampshire	Mid Atlantic Concrete Equipment	P.O. Box 36	Lititz, PA	17521	888.378.6237
	parts@maconcrete.com	www.maconcrete.com			888.378.6223 - Fax
New Jersey	Mid Atlantic Concrete Equipment	P.O. Box 36	Lititz, PA	17521	888.378.6237
	parts@maconcrete.com	www.maconcrete.com			888.378.6223 - Fax
New Mexico	Faris Machinery Company	5770 East 77th Avenue	Commerce City, CO	80022	800.551.7768
	dmansheim@farismachinery.com	www.farismachinery.com			303.287.9273 - Fax
New York	Mid Atlantic Concrete Equipment	P.O. Box 36	Lititz, PA	17521	888.378.6237
	parts@maconcrete.com	www.maconcrete.com			888.378.6223 - Fax
North Carolina	Concrete Equipment Supply, LLC	PO Box 7 8700 Traid Dr	Colfax, NC	27235	800.680.5604
	Jhanson@concreteequipmentsupply.com	www.concreteequipmentsupply.com			704.360.2673 - Fax
North Dakota	Advanced Technical Services, Inc.	702 LeClair Street	Cedar Falls, IA	50613	888.296.7278
	parts@ats-inc.net	www.ats-inc.net			
Ohio	Concrete Machinery Company, LLC	PO Box 10348	Murfreesboro TN	37129	319.505.3526
	chris@concretemachinery.co				

RexCon® Dealer Locator (Listed by State)					
Phone number for Sales Department: 262.539.4550					
State	Distributor / Email Address	Address / Website	City, State	ZIP Code	Phone
Oklahoma	Faris Machinery Company	5770 East 77th Avenue	Commerce City, CO	80022	800.551.7768
	dmansheim@farismachinery.com	www.farismachinery.com			303.287.9273 - Fax
Oregon	CONAGSCO	P.O. Box 225	Harrington, WA	98134	800.326.1950
	parts@conagsco.com	www.conagsco.com			800.326.1950 - Fax
Pennsylvania	Mid Atlantic Concrete Equipment	P.O. Box 36	Lititz, PA	17521	888.378.6237
	parts@maconcrete.com	www.maconcrete.com			888.378.6223 - Fax
Rhode Island	Mid Atlantic Concrete Equipment	P.O. Box 36	Lititz, PA	17521	888.378.6237
	parts@maconcrete.com	www.maconcrete.com			888.378.6223 - Fax
South Carolina	Concrete Equipment Supply, LLC	PO Box 7 8700 Traid Dr	Colfax, NC	27235	800.680.5604
	Jhanson@concreteequipmentsupply.com	www.concreteequipmentsupply.com			704.360.2673 - Fax
South Dakota	TransSource Truck & Equipment	901 E 60th Street North	Sioux Falls, SD	57104	800.289.6225
	sfparts@transourceusa.com	www.transourceusa.com			605.229.2248 - Fax
Tennessee	Southern Concrete Machinery, LLC	PO Box 11098	Murfreesboro, TN	37129	833-4CON-ECO
	chris@southernconcretemachinery.com	www.SouthernConcreteMachinery.com			615.957.4600 - Cell
Texas	Closner Equipment	6532 E State HWY 114	Rhome, TX	76078	817.708.9108
	bsmith@closner.com	www.closner.com			
Utah	Faris Machinery Company	5770 East 77th Avenue	Commerce City, CO	80022	800.551.7768
	dmansheim@farismachinery.com	www.farismachinery.com			303.287.9273 - Fax
Vermont	Mid Atlantic Concrete Equipment	P.O. Box 36	Lititz, PA	17521	888.378.6237
	parts@maconcrete.com	www.maconcrete.com			888.378.6223 - Fax
Virginia	Mid Atlantic Concrete Equipment	P.O. Box 36	Lititz, PA	17521	888.378.6237
	parts@maconcrete.com	www.maconcrete.com			888.378.6223 - Fax
Washington	CONAGSCO	P.O. Box 225	Harrington, WA	98134	800.326.1950
	parts@conagsco.com	www.conagsco.com			800.326.1950 - Fax
Washington, DC	Mid Atlantic Concrete Equipment	P.O. Box 36	Lititz, PA	17521	888.378.6237
	parts@maconcrete.com	www.maconcrete.com			888.378.6223 - Fax
West Virginia	Mid Atlantic Concrete Equipment	P.O. Box 36	Lititz, PA	17521	888.378.6237
	parts@maconcrete.com	www.maconcrete.com			888.378.6223 - Fax
Wisconsin	Advanced Technical Services, Inc.	702 LeClair Street	Cedar Falls, IA	50613	888.296.7278
	parts@ats-inc.net	www.ats-inc.net			
Wyoming	Faris Machinery Company	5770 East 77th Avenue	Commerce City, CO	80022	800.551.7768
	dmansheim@farismachinery.com	www.farismachinery.com			303.287.9273 - Fax

How to Use This Catalog

The primary heading in the Table of Contents corresponds with the category description on the edge of each page. The secondary headings in the Table of Contents correspond with the horizontal headings on the parts page. Each secondary heading lists the page in the catalog where it can be found.

How to Order

This catalog contains the most frequently ordered parts for RexCon batch plants and mixers.

You have a choice of who to contact for any of the parts in this catalog. Parts may be ordered from either the inside sales team or the outside territory sales rep. See preceding page for contact information.

When ordering parts for your plant, the plant's model and serial number may be required. The serial number is located on the columns of the plant or name plate, or is engraved in the main control panel.

If you wish to place an order after hours, email us at parts.burlington@astecindustries.com and we will place the order as soon as possible.

CFI or OIR

When ordering parts, some are complicated with many options and variations or are no longer available. To identify these parts, an acronym has been used in the Part No. field. Two acronyms have been used and are identified as follows:

- CFI** Contact For Information
- OIR** Order Information Required)

Reference the example below for the location of the acronym:

EXAMPLE:

Description	RexCon® Part No.
Antenna	<i>CFI*</i>

CFI

A **CFI** indicates additional specifications are required. Please contact your RexCon® Distributor for further details. When a **CFI** is referenced, a table with a specific definition will follow.

EXAMPLE:

CFI - Contact for Information
Specifications required when ordering complete units. Please contact your RexCon® Distributor for further details.

OIR

An **OIR** indicates specific information in addition to the Part No. is required when ordering. When an **OIR** is referenced, a table with the specific information is identified.

EXAMPLE:

OIR - Ordering Information Required
When ordering item "A", the discharge opening size, 24" or 30", must be specified.

Pre-Cut Lengths

3/16" Wall, Vulcanized Seams



BOOTS

Description	RexCon® Part No.
5.75" Diameter x 24" Long	102-02347-50
6.5" Diameter x 12" Long	102-02347-55
7" Diameter x 24" Long	102-02347-46
8.25" Diameter x 8" Long	102-02347-37
8.25" Diameter x 12" Long	102-02347-39
8.25" Diameter x 18" Long	102-02347-53
8.25" Diameter x 24" Long	102-02347-36
8.25" Diameter x 28" Long	102-02347-17
8.25" Diameter x 30" Long	102-02347-01
8.25" Diameter x 36" Long	102-02347-02
8.25" Diameter x 40" Long	102-02347-21
8.25" Diameter x 48" Long	102-02347-03
8.25" Diameter x 53" Long	102-02347-38
8.25" Diameter x 60" Long	102-02347-26
8.25" Diameter x 72" Long	102-02347-47
9.25" Diameter x 24" Long	102-02347-58
10" Diameter x 8" Long	102-02347-76
10" Diameter x 10" Long	102-02347-71
10" Diameter x 12" Long	102-02347-74
10" Diameter x 16" Long	102-02347-77
12" Diameter x 12" Long	102-02347-54
12" Diameter x 14" Long	102-02347-04
12" Diameter x 40" Long	102-02347-20
12" Diameter x 48" Long	102-02347-45
12" Diameter x 72" Long	102-02347-43
18" Diameter x 24" Long	102-02347-05
18" Diameter x 36" Long	102-02347-25
18" Diameter x 42" Long	102-02347-23
20" Diameter x 17" Long	102-02347-06
20" Diameter x 18" Long	102-02347-52
20" Diameter x 24" Long	102-02347-40
20" Diameter x 28" Long	102-02347-07
20" Diameter x 30" Long	102-02347-11
20" Diameter x 32" Long	102-02347-19
20" Diameter x 34" Long	102-02347-30
20" Diameter x 36" Long	102-02347-12
20" Diameter x 40" Long	102-02347-28
20" Diameter x 53" Long	102-02347-41
22" Diameter x 9" Long	102-02347-48
22" Diameter x 15" Long	102-02347-08
22" Diameter x 18" Long	102-02347-09
22" Diameter x 22" Long	102-02347-18
22" Diameter x 24" Long	102-02347-10

Gum Rubber

BOOTS

Pre-Cut Lengths, continued

Description	RexCon® Part No.
22" Diameter x 28" Long	102-02347-16
22" Diameter x 30" Long	102-02347-13
22" Diameter x 32" Long	102-02347-29
22" Diameter x 34" Long	102-02347-27
22" Diameter x 36" Long	102-02347-15
22" Diameter x 45" Long	102-02347-44
22" Diameter x 60" Long	102-02347-32
22" Diameter x 66" Long	102-02347-31
22" Diameter x 72" Long	102-02347-56
24" Diameter x 9" Long	102-02347-49
24" Diameter x 18" Long	102-02347-51
24" Diameter x 20" Long	102-02347-34
24" Diameter x 24" Long	102-02347-42
24" Diameter x 30" Long	102-02347-22
24" Diameter x 36" Long	102-02347-35
24" Diameter x 42" Long	102-02347-57
24" Diameter x 50" Long	102-02347-33
28" Diameter x 40" Long	102-02347-24
36" Diameter x 24" Long	102-02347-14

Bulk Sizes

Description	RexCon® Part No.
Rubber tube, 8" (per foot)	102-02347-408
Rubber tube, 10" (per foot)	102-02347-410
Rubber tube, 12" (per foot)	102-02347-412
Rubber tube, 20" (per foot)	102-02347-420
Rubber tube, 22" (per foot)	102-02347-422
Rubber tube, 24" (per foot)	102-02347-424
Rubber tube, 26" (per foot)	102-02347-426

Custom Cylinder Information

Note: This Reference Sheet can be used to order replacement cylinders not shown in this catalog. Please provide the following information.

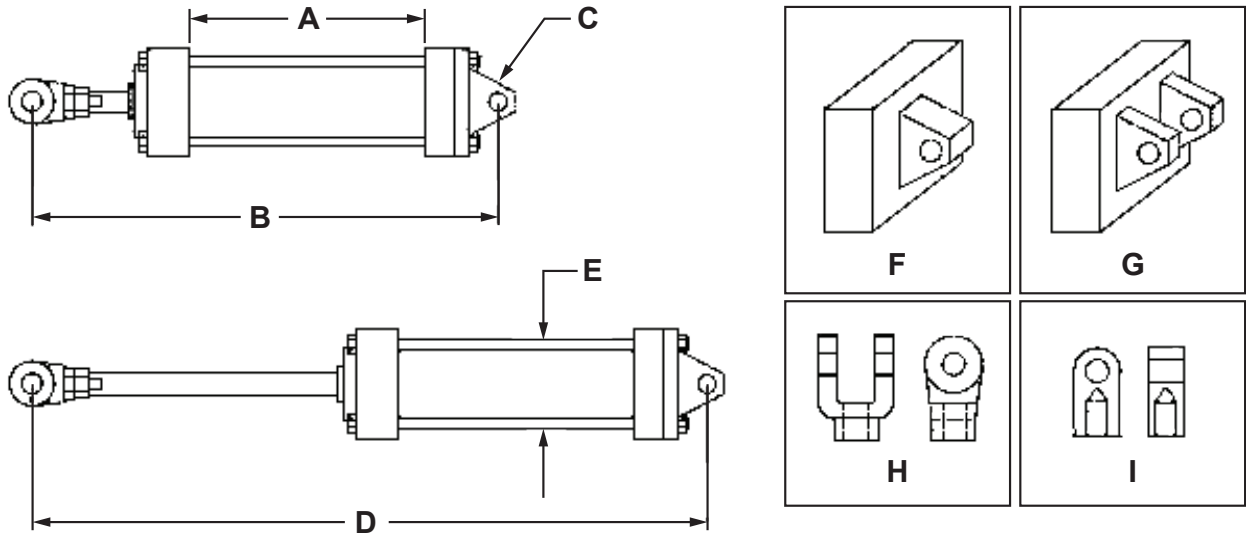

Ordering Dimensions

ID	Description
A	Cylinder Body Length
B	Cylinder Length (Retracted) -- Mounting Pin Center-to-Center
C	Mounting Pin Diameter (Front & Rear)
D	Cylinder Length (Extended) -- Mounting Pin Center-to-Center
E	Approximate Cylinder Diameter

Mounting Hardware

ID	Description
F	Mounting Bracket Style (Single Tang)
G	Mounting Bracket Style (Double Tang)
H	Rod Clevis Style (Rod Clevis)
I	Rod Clevis Style (Rod Eye)

Cylinders

PNEUMATICS

Air Cylinders



Size	RexCon® Part No.	Repair Kit Part No.
2" x 4"	298-03001-01	298-00119-01
2.5" x 5"	298-03016-01	298-00120-01
2.5" x 6"	212-03016-01	298-00120-01
2.5" x 8"	298-03004-01	298-00120-01
2.5" x 9"	212-03023-01 Tel. Boot	298-00120-01
2.5" x 10"	298-03010-01	298-00120-01
2.5" x 12"	298-03017-01	298-00120-01
2.5" x 18"	212-03009-01 Tel. Boot	298-00120-01
2.5" x 22"	212-03031-01	298-00120-01
2.5" x 24"	212-03003-01 Tel. Boot	298-00120-01
3" x 10"	298-03005-01	298-00124-01
3" x 12"	298-03019-01	298-00124-01
3" x 18"	298-03018-01	298-00124-01
4" x 6"	298-03007-01	298-00121-01
4" x 8"	212-03005-01	298-00121-01
4" x 9"	212-03042-01	298-00121-01
4" x 10"	298-03008-01	298-00121-01
4" x 12"	298-03015-01	298-00121-01
4" x 15"	298-03009-01	298-00121-01
4" x 18"	298-03014-01	298-00121-01

Hydraulic Cylinders



Size	RexCon® Part No.	Seal Kit
7.5" x 19.5"	102-08171-02	Pre-1987: P298-00685-00 1987 & later: 298-00709-00
6.5" x 19.5"	112-05124-02	112-05124-10
5" x 40"	212-03134-53	212-03135-53

Description	Part No.
Spherical Bearing	298-06800-08
Snap Ring	298-07518-34

Pins

Note: Cylinder Mounting Pin is for **Tilt Mixers only**.



Cylinder Mounting Pin



Tilt Frame Lock Pin

Description	RexCon® Part No.
Cylinder Mounting Pin, 15" (Bottom)	502-03882-80
Cylinder Mounting Pin, 12" (Upper)	502-03882-81
Tilt Frame Lock Pin Assembly	644-15134-03
Tilt Frame Lock Pin	524-14646-80

Air Treatment

Air Valves

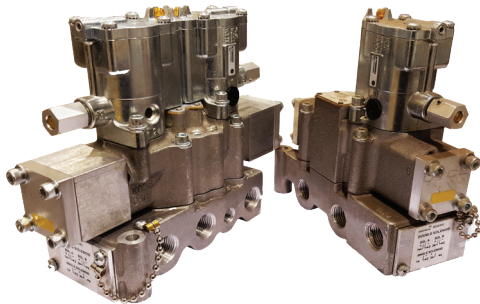

Parker Double Solenoid Valve

Parker Single Solenoid Valve



SMC Double Solenoid Valve

SMC Single Solenoid Valve

Description	RexCon® Part No.
Parker Valves	
3/8"	
3/8" Single	212-02147-01
3/8" Single Solenoid Rebuild Kit	212-02149-01
3/8" Double	212-02146-01
3/8" Double Solenoid Rebuild Kit	212-02148-01
Solenoid Coil	212-02095-01
1/2"	
1/2" Single	212-02108-01P
1/2" Single Solenoid Rebuild Kit	212-02114-01N
1/2" Double	212-02109-01P
1/2" Double Solenoid Rebuild Kit	212-02115-01N
Solenoid Coil	298-00134-00
SMC Valves	
1/2" Single	212-02108-01N
1/2" Double	212-02109-02
Components	
3/8" Flow Control Muffler	212-02145-01
1/2" Flow Control Muffler	212-02110-01
1/4" Poppet Valve	212-02131-01
3/4" Poppet Valve	212-02025-01

Air & Hydraulic Valves

Description	RexCon® Part No.
Holding Valve: Old Style, Low Pressure	212-00233-53
Counterbalance Valve, Upper: New Style	212-11095-53
Holding Valve, Lower: New Style	212-11086-53
Pilot Valve, 3/8", 3-Position, 4-Way	212-02132-01
1/2" Lubricator	212-02139-01
1/2" In-Line Air Filter	212-02029-01
1/2" Regulator with Gauge	212-02030-01



Holding Valve: Old Style, Low Pressure

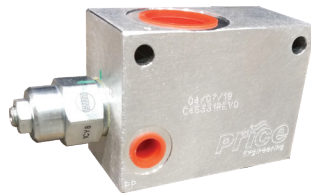

Counterbalance Valve, Upper: New Style

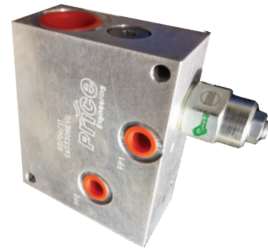

Holding Valve, Lower: New Style

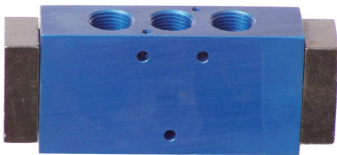

Pilot Valve



Lubricator



In-Line Air Filter



Regulator with Gauge

Replacement Filters

DUST COLLECTION

Bags (for RA and BP units)



Description	RexCon® Part No.
6" x 5' Bag for BP	B0007
6" x 10' Bag for BP (120" long)	B0118 (B0006)*
6" x 12' Bag for BP (144" long) (BP1800 & 2450)	B0012
Cage with Venturi for 6" x 5' Bags for BP	B0008
Cage with Venturi for 6" x 10' Bags for BP	B0005
Cage with Venturi for 6" x 12' Bags for BP	B0013
8" x 114" Bag for RA	B0117 (B0001)*
8" x 69" Bag for Old Style RA Units	B0000
8" x 138" Bag for RA-170 & RA-340	B0119 (B0011)*
4" x 78" Bag - Silo Shaker SK250	B0014

*Part numbers in parentheses, such as (B0001), are legacy part numbers.

Cartridges (for CP units)



Description	RexCon® Part No.
12-3/4" x 27" Cartridge (CP-100)	CD002
8" x 19" Cartridge (CP-35, CP-70, CP-88)	CD121 (CD028)*
8" x 39" Cartridge	CD122 (CD029)*
8" x 54" Cartridge	CD123 (CD031)*
8" x 78" Cartridge	CD124 (CD033)*
Rubber Seal (one is provided with each new cartridge; order if you need extras)	CD035
Felt Plug (used in the LPR series to close an unused cartridge hole)	CD014
Cartridge Removal Tool	41060177

*Part numbers in parentheses, such as (CD028), are legacy part numbers.

Return Blowers & Parts

Description	RexCon® Part No.
Return Blower, Filter, and 1 Qt of Oil	RT020 Kit
2" Return Blower Filter with Housing	RT019

Couplings



Description	RexCon® Part No.
3/4" 6JX Coupling	CP004
1-3/8" 6JX Coupling	CP001
Spider 6JE Coupling	CP003

Electrical Timers

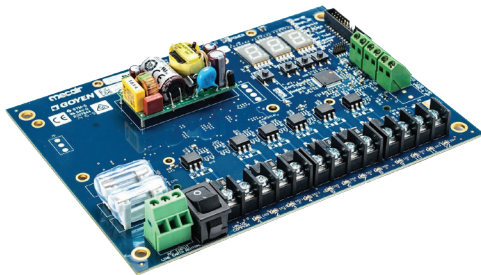

4-12 Pole Digital Timer Board - Goyen

Description	RexCon® Part No.
360-120-1 - Second 8 Pin	ET000
360-120-1 - Minute 8 Pin	ET001
360-120-1 - Second	ET002
TM 261S-120 - 2 Stage Alternator 8 Pin	ET003
120V Relay - 8501 KPIZV	ET004
368-120-1 - Second (Double Timer) 8 Pin	ET006
Goyen 4 Pole Time Board 12V	ET010
361-120-1 Minute Timer	ET011
4-12 Pole Digital Timer Board - Goyen (for Central)	ET077
E/T Socket 8 Pin	ET012

Butterfly Valves & Parts



Description	RexCon® Part No.
Bray 6" Butterfly Valve	41060171
Bray 8" Butterfly Valve	41060310
Bray 6" Butterfly Valve Actuator	BF007
Bray 8" Butterfly Valve Actuator	41060114
Bray 6" Butterfly Adapter	BF002
Bray Manual Lever Butterfly Valve	BF008
WAM 6" Butterfly Valve	BF005
WAM 8" Butterfly Valve	BF006
WAM Butterfly Valve Actuator	BF009



1" Threaded Solenoid Valve



1/4" Solenoid Valve with 6' Cable and Steel Cord Grip



Turbo 1-1/2" Diaphragm Repair Kit

Description	RexCon® Part No.
3/4" Solenoid Valve (Compression)	41060280
3/4" Solenoid Valve to Convert Asco to Turbo	S0026-N
1" Solenoid Valve (this solenoid was also used on LPR units until July 2007)	S0002
1" Immersion Solenoid Valve for CP-305TT units	41060186
1-1/2" Solenoid Valve	S0010
1" Threaded Solenoid Valve (used on LPR units from July 2007 to current)	41060173
3/4" Double Bulkhead (MID)	S0012
1" Double Bulkhead (MID)	S0014
1-1/2" Double Bulkhead (MID)	S0025
3/4" Threaded Solenoid Valve for CP-35, CP-70, CP-88	S0008
1/4" Solenoid Valve with 6' Cable and Steel Cord Grip	S0045
1/4" Solenoid Coil with Cord and Cable	S0046
Inching Solenoid Valve	S0080
Pole Assembly for 3/4", 1", and 1-1/2" Solenoids	41060175
Coil for 3/4", 1", and 1-1/2" Solenoids	41060187
Turbo 3/4" and 1" Diaphragm Repair Kit	41060174
Turbo 1-1/2" Diaphragm Repair Kit	S0031
3' Din Cord - E/W Solenoid Connector	EW015
6' Din Cord - E/W Solenoid Connector	EW016
Relief Valve for air/pulse tanks on CP units	VA016

Aggregate Bin Clamshell Gates

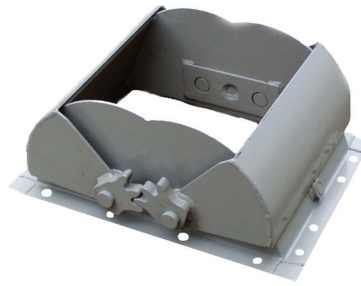

Top Opening to Flange	Sides	RexCon® Body Part No.	RexCon® Leaf & Segment Part No.	RexCon® Assembly Part No.
Tapered				
24" x 18" x 16"	Tapered	512-05623-80	512-05624-80	612-04417-02
24" x 16" x 16"	Tapered	512-05623-81	512-05624-81	612-04417-03
24" x 24" x 16"	Tapered	512-05623-84	512-05624-83	612-04417-01
Straight				
18" x 18"	Straight	512-04296-80	512-05624-80	612-04621-01
16" x 16"	Straight	512-05623-82	512-05624-81	612-04417-04
15" x 15"	Straight	512-10134-80	512-05624-84	612-01155-01
14" x 14"	Straight	512-05623-83	512-05624-82	612-04417-05

Other sizes available but not listed. Please call the RexCon Parts Department for more information.

Gate Accessories



Description	RexCon® Part No.
Gate Pivot Pin	112-02744-01
Roll Pin	298-06007-34
Clevis Pin	112-01732-02
Gear Segment	112-04120-01
4" Cylinder Anchor	112-01486-01
4" Cylinder Anchor Stud	102-00161-01
4" Cylinder Anchor Stud Nut	398-11000-32
3" Cylinder Anchor	102-00033-01
3" Cylinder Anchor Stud	102-00156-01
3" Cylinder Anchor Stud Nut	398-11000-08

Assemblies

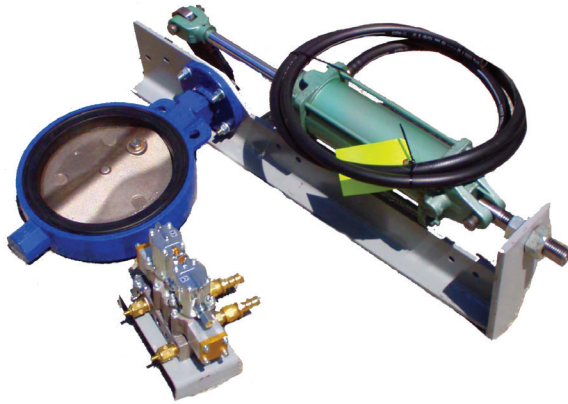

Description	RexCon® Part No.
10" Gate, 1/2" Single Solenoid Assembly	602-20113-01
10" Gate, 1/2" Double Solenoid Assembly	602-20113-03
10" RH Cylinder Arm	512-04640-80
10" LH Cylinder Arm	512-04640-81
6" RH Cylinder Arm	512-01937-80
3" RH Cylinder Arm	512-01932-80

Conversion Kits

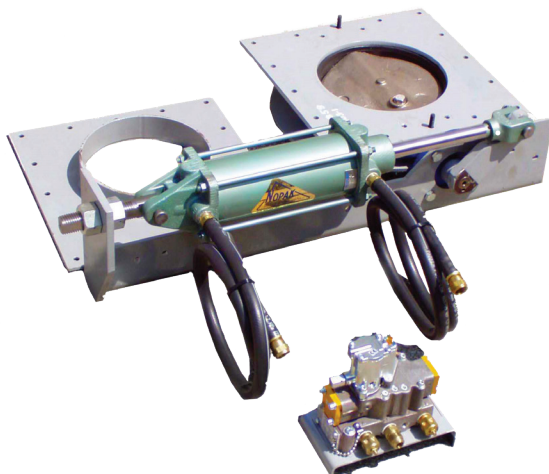

Description	RexCon® Part No.
10" Gate, 1/2" Single Solenoid Conversion Kit with Adapter Plates	702-04303-01
10" Gate, 1/2" Double Solenoid Conversion Kit with Adapter Plates	702-04305-01

Crane® Center Line



Size	RexCon® Butterfly Valve Part No.	RexCon® Air Cylinder Part No.	RexCon® Replacement Seat Part No.
10"	112-04355-01	212-03005-01	298-00201-00
8"	212-14063-86	—	—
6"	212-14030-86	212-03016-01	298-00180-00
5"	212-14064-86	—	—
4"	212-14032-86	—	298-00202-00
3"	212-14028-86	212-03016-01	298-00179-00

Keystone®

Size	RexCon® Butterfly Valve Part No.	RexCon® Valve with Actuator Part No.	RexCon® Actuator Only Part No.	RexCon® Replacement Seat Part No.
12"	212-00053-98	—	—	—
10"	102-12677-01	212-01101-98	B2H-38-8-11	298-00855-00
6"	B2H-38-8-10	212-00054-98	B2H-38-8-11	B2H-38-8-13
3"	102-31770-10	102-31770-01	102-31770-12	102-31770-11

Description	RexCon® Part No.
Solenoid only	102-31770-23

Bray®



Size	RexCon® Valve with Actuator Part No.
10"	212-01101-98B
6"	212-00054-98B
3"	102-31770-01B

Description	RexCon® Part No.
Solenoid for 3", 6", 10" Bray Valves	212-01109-98-02

Bin Level Indicators

Description	RexCon® Part No.
Bin Level Indicator, Paddle Type	212-02168-56
Bin Level Indicator, Banana Type	614-13132-04
Bin Level Indicator, Tilt Type	212-02096-56
Bin Level Indicator, Monitor 3-Vane Paddle Type	212-02034-56



Bin Level Indicator, Paddle Type



Bin Level Indicator, Banana Type



Bin Level Indicator, Tilt Type

Vibrators

Description	RexCon® Part No.
Cement Vibrator with Muffler	212-02138-01
Aggregate Vibrator with Muffler	212-03047-01



Cement Vibrator with Muffler



with Muffler

Aeration Components



Description	RexCon® Part No.
Bin Flo Pad Kit (includes the five items listed below)	612-02610-06
Bin Flo Pad	298-02016-01
Adapter Clamp	112-08128-01
3/16" Gasket	112-08128-03
1/16" Gasket	112-08128-04
Final Clamp	112-08128-02

Blowers & Valves

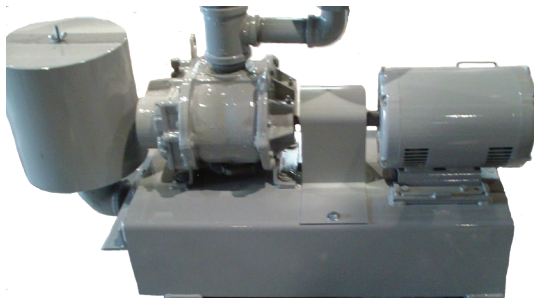

Standard Blower Assembly

Description	RexCon® Part No.
Standard Blower Assembly	602-02140-04
Motor	212-00068-20
Coupler	102-11639-01
Air Blower	298-01009-01
Relief Valve	298-00185-00
Filter	298-00149-00
Regenerative Blower Assembly	602-02140-10
Filter	602-02140-07-03
Breaker	20-05150-08
Contactors	20-18275-9
Solenoid Valve	298-02106-01
Coil Only	298-15077-17
1/8" Needle Valve	212-02016-01



Regenerative Blower Assembly

Idlers

Troughing & Return Idlers

20°, 30°, and 45° are available in various sizes of Rollers, but not shown.

Description	RexCon® Part No.
45° Troughing Roller	102-11589-03
35° Troughing Roller	114-12103-02
20° Troughing Roller	102-11589-01
5" Return Roller	102-11589-11
4" Return Roller	102-11032-01

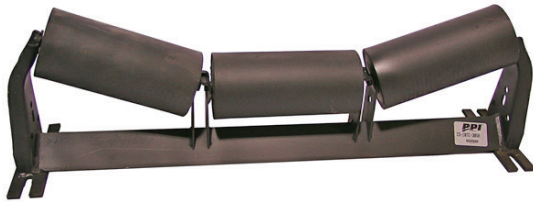

Troughing Roller

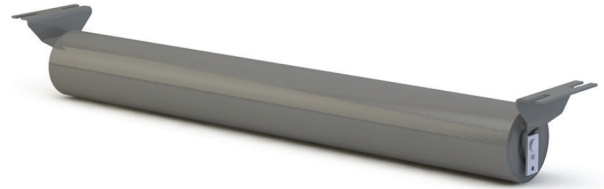

Return Roller

Pulleys

We have many types available. Please call 262-539-4550 to discuss your specific needs.



Lagged Head Pulley



Herringbone Wing Pulley

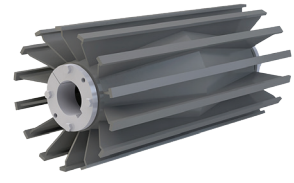

Winged Tail Pulley

Conveyor Belt Wipers

New Spring Loaded Wipers

Description	RexCon® Part No.
Spring Loaded Wiper	212-03140-14



AGGREGATE CONVEYORS

Conveyor Accessories

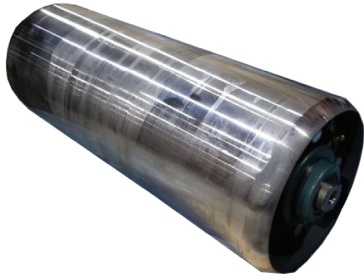

Hold Down Roller



48" Belt Blade Replacement

Description	RexCon® Part No.
Hold Down Roller	612-02630-01
Hold Down Roller Bracket	512-04311-80
48" Pole Support	212-03140-14-01
Mounting Plate Kit (2)	212-03140-14-02
Torque Arm Kit	212-03140-14-03
Pivot Shaft Bracket Kit	212-03140-14-04
Pivot Block Kit	212-03140-14-05
Pivot Rod Kit	212-03140-14-06
Bushing Kit Purple (2)	212-03140-14-07
Tension Spring Purple	212-03140-14-08
Pole Lock	212-03140-14-09
Blade Pin	212-03140-14-10
48" Belt Blade Replacement	212-03140-14-11

Mixer Drive Assemblies

Drum Size (YD)	Motor HP	Blade Style	Side	Assembly Part No.	Motor Part No.	Reducer Part No.	20T Pinion Part No.	QD Bushing Part No.	Omega Coupling Part No.
12L	125	Spiral	F1	612-05352-01	212-00253-20	212-04584-91	412-01520-02	212-08144-91	112-08418-04
12L	125	Spiral	F2	612-05352-02	212-00254-20	212-04584-91	412-01520-02	212-08144-91	112-08418-04
12S	125	Extended	F1	612-05352-01	212-00253-20	212-04584-91	412-01520-02	212-08144-91	112-08418-04
12S	125	Extended	F2	612-05352-02	212-00254-20	212-04584-91	412-01520-02	212-08144-91	112-08418-04
12	100	Spiral	F1	612-05352-04	112-08308-10	212-04580-91	412-01520-02	212-08144-91	112-08418-04
12	100	Spiral	F2	612-05352-03	112-08308-09	212-04580-91	412-01520-02	212-08144-91	112-08418-04
12	100	Standard	F1	612-05352-04	112-08308-10	212-04580-91	412-01520-02	212-08144-91	112-08418-04
12	100	Standard	F2	612-05352-03	112-08308-09	212-04580-91	412-01520-02	212-08144-91	112-08418-04
12	60	Standard	F1	612-05352-06	112-08308-08	212-04579-91	412-01520-02	212-08140-91	112-08418-01
12	60	Standard	F2	612-05352-05	112-08308-07	212-04579-91	412-01520-02	212-08140-91	112-08418-01
10	60	Standard	F1	612-05352-06	112-08308-08	212-04579-91	412-01520-02	212-08140-91	112-08418-01
10	60	Standard	F2	612-05352-05	112-08308-07	212-04579-91	412-01520-02	212-08140-91	112-08418-01
10	50	Standard	F1	612-05352-08	112-08308-06	212-04579-91	412-01520-02	212-08140-91	112-08418-02
10	50	Standard	F2	612-05352-07	112-08308-05	212-04579-91	412-01520-02	212-08140-91	112-08418-02
8	50	Standard	F1	612-05352-08	112-08308-06	212-04579-91	412-01520-02	212-08140-91	112-08418-02
8	50	Standard	F2	612-05352-07	112-08308-05	212-04579-91	412-01520-02	212-08140-91	112-08418-02

TEFC Drive Parts

Drum Size (YD)	Motor HP	Blade Style	Side	Assembly Part No.	Motor Part No.	Reducer Part No.	20T Pinion Part No.	QD Bushing Part No.	Omega Coupling Part No.
12	100	Spiral	F1	612-05352-30	212-00256-20	212-04580-91	412-01520-02	212-08144-91	112-08418-04
12	100	Spiral	F2	612-05352-29	212-00257-20	212-04580-91	412-01520-02	212-08144-91	112-08418-04
12	100	Standard	F1	612-05352-30	212-00256-20	212-04580-91	412-01520-02	212-08144-91	112-08418-04
12	100	Standard	F2	612-05352-29	212-00257-20	212-04580-91	412-01520-02	212-08144-91	112-08418-04
12	60	Standard	F1	612-05352-26	212-00218-20	212-04580-91	412-01520-02	212-08144-91	112-08418-04
12	60	Standard	F2	612-05352-25	212-00219-20	212-04580-91	412-01520-02	212-08144-91	112-08418-04

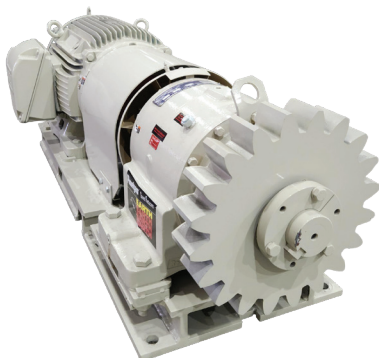

TEFC Drive Assemblies

Motor HP	RPM	Electrical	Side	RexCon® Part No.
60	1750	230/460/3/60	F2	212-00219-20
60	1750	230/460/3/60	F1	212-00218-20
100	1750	230/460/3/60	F2	212-00257-20
100	1750	230/460/3/60	F1	212-00256-20

Power Transmission

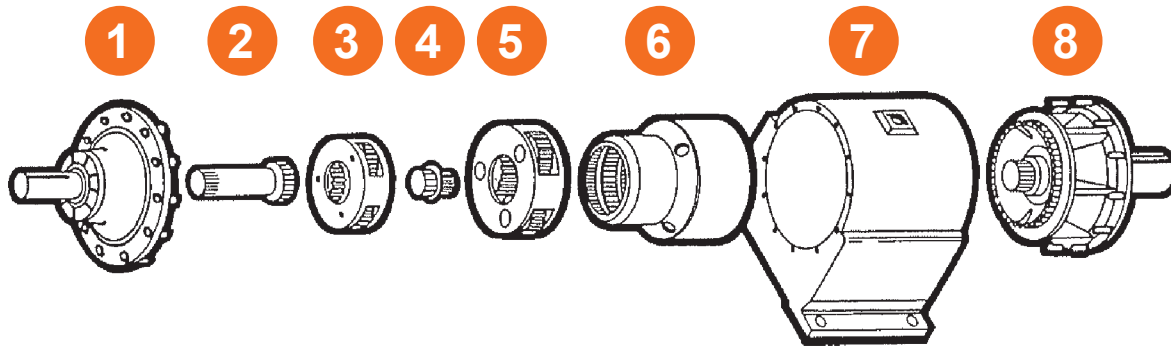

Double Reduction

ITEM #	Description	Part Number (Polaris, 16.93)	Part Number (Earth, 16.93)	Part Number (Earth, 19.05)
1	Input Sub-Assembly	212-05643-68	212-05643-68	212-05643-68
2	Input Gear	212-05637-68	212-05653-68	212-05662-68
3	Carrier Sub-Assembly	212-05638-68	212-05654-68	212-05659-68
4	Sun Gear	212-05639-68	212-05655-68	212-05661-68
5	Carrier Sub-Assembly	212-05640-68	212-05656-68	212-05660-68
6	Ring Gear	212-05641-68	212-05657-68	212-05641-68
7	Main Case	-	-	-
8	Output Sub-Assembly	212-05645-68	212-05644-68	212-05644-68

Input Assembly

All Rexnord Reducers

Description	RexCon® Part No.
Input Shaft	212-05626-68
Outer Seal	212-03013-68
Inner Seal	212-03014-68
Input Seal Carrier	212-05627-68
Bearing Cone, Outer	212-03024-68
Bearing Cup, Outer	212-03023-68
Bearing Cone, Inner	212-03019-68
Bearing Cup, Inner	212-03020-68
Input Spacer	212-05628-68
Input Washer	212-05629-68
Input Nut	212-05630-68

Output Assembly

Description	Polaris Part No.	All Earth Reducers Part No.
Output Shaft	212-05646-68	212-05632-68
Outer Seal	212-05624-68	212-03016-68
Inner Seal	212-05623-68	212-03015-68
Output Seal Carrier	212-05651-68	212-05635-68
Bearing Cone, Outer	212-00279-68	212-03021-68
Bearing Cup, Outer	212-00280-68	212-03022-68
Bearing Cone, Inner	212-00277-02	212-03017-68
Bearing Cup, Inner	212-00278-68	212-03018-68
Retaining Ring	212-05646-68	212-05632-68
Output Washer	212-05648-68	212-05642-68
Output Nut	212-05647-68	212-05633-68

Reducers/Drivers



Pinion



Rexnord Earth Drive

Description	RexCon® Part No.
Drive Mount Update Kit	D3H-33-286
Fan, Earth	212-04579-EFAN
Fan, Polaris	212-04584-PFAN
Fan & Shroud Kit, Earth	212-04579-EFS
Fan & Shroud Kit, Polaris	212-04584-PFS

Pinion	RexCon® Part No.
For use with Rockwell Reducer	402-01710-02
For use with Rexnord Reducer	412-01520-02
Rockwell to Rexnord Drive Update Kit	CFI*
Bushing, 3-1/2" Bore	212-08140-91
Bushing, 4" Bore	212-08144-91

CFI - Contact for Information

Kits are available to update from Rockwell to Rexnord drives. Please contact your RexCon® Distributor for further details.

Reducer/Driver	HP	RexCon® Part No.
Polaris Drive	125	212-04584-91
Earth Drive	100	212-04580-91
Earth Drive	60	212-04579-91

Standard Drive Motors



HP	RPM	Electrical	Side	RexCon® Part No.
Tilt Mixer Drives				
50	1750	230/460/3/60	F2	112-08308-05
50	1750	230/460/3/60	F1	112-08308-06
60	1750	230/460/3/60	F2	112-08308-07
60	1750	230/460/3/60	F1	112-08308-08
100	1750	230/460/3/60	F2	112-08308-09
100	1750	230/460/3/60	F1	112-08308-10
125	1750	230/460/3/60	F2	212-00254-20
125	1750	230/460/3/60	F1	212-00253-20
TEFC Drives				
60	1780	230/460/3/60	F2	212-00219-20
60	1780	230/460/3/60	F1	212-00218-20
100	1780	230/460/3/60	F2	212-00257-20
100	1780	230/460/3/60	F1	212-00256-20

Detachable Discharge Cone



Description	Drum Size	Qty	RexCon® Part No.
Detachable Discharge Cone	6 - 12M	1	502-03876-80
Poly Liner - Cone	6 - 12M	8	102-31436-01
Steel Liner - Cone	6 - 12M	6	112-04714-01
Steel Capacity Blade	6 - 12M	4	502-05962-80
Poly Lined Capacity Blade	6 - 12M	4	502-05962-POLY
Standard 12yd Detachable Cone Assembly			644-15559-01
39-1/2" Opening 12yd Detachable Cone Assembly			644-15559-02

Detachable Cone Latch Kit



Description	Drum Size	Qty	RexCon® Part No.
Latch Kit		1	712-00913-01
Latch		8	502-02107-80
Pin		8	102-06240-01
1" Sq. Head Bolt		8	112-07767-01
1" Jam Nut		8	398-11000-58
Cottern Pin		16	398-03000-14

Charge & Discharge Cones

TILT MIXERS

Standard Drum Assembly



Drum Size	Wrapper size	Blade Style	Drum Liner	Blade Liner	RexCon® Part No.
12L	3/4"	Spiral	Poly	Steel	612-05355-24
12L	3/4"	Spiral	Poly	Wrap	612-05355-38
12S	3/4"	Standard	Poly	Steel	612-05355-26
12S	3/4"	Standard	Poly	Wrap	612-05355-35
12	3/4"	Spiral	Poly	Steel	612-05355-22
12	3/4"	Spiral	Poly	Wrap	612-05355-28
12	3/4"	Standard	Poly	Steel	612-05355-19
12	3/4"	Standard	Poly	Wrap	612-05355-21
12	3/4"	Standard	Poly	Chromium	612-05355-40
10	3/4"	Standard	Poly	Steel	612-05355-31
10	3/4"	Standard	Poly	Wrap	612-05355-33
8	3/8"	Standard	Poly	Steel	612-05355-10
8	3/8"	Standard	Poly	Poly	612-05355-11

Charge & Discharge Cones

Poly Charge Cone Adapter



Description	Qty	RexCon® Part No.
Poly Adapter Charge Cone Kit: includes Poly Adapter (502-03878-POLY), 3 retainer seals, and hardware		644-10241-01
Poly Charge Cone Adapter, 6 - 12M	1	502-03878-POLY
Retainer	3	134-10240-01
3/8" Bolt	18	298-00109-93
3/8" Flat Washer	18	398-20000-23
3/8" Nut	18	398-11000-19
3/8" Lock Washer	8	398-20000-37

Charge Chutes

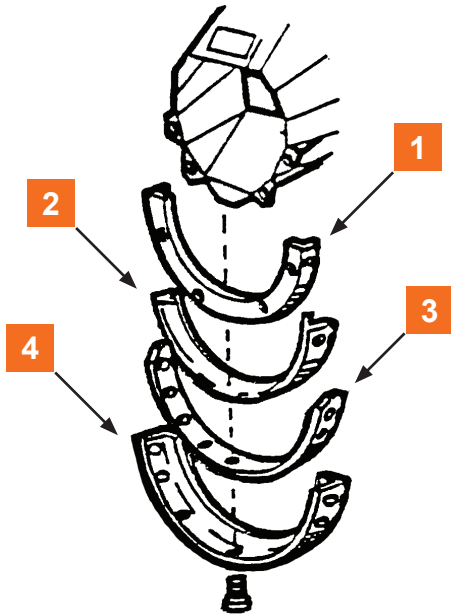

Item #	Description	RexCon® Part No.
1	38" Seal Ring Adaptor	112-04160-02
2	38" Inner Seal	112-02416-01
3	38" Outer Seal	112-02417-01
4	38" Retainer	112-04230-01

Rollers

TILT MIXERS

Edge Rollers

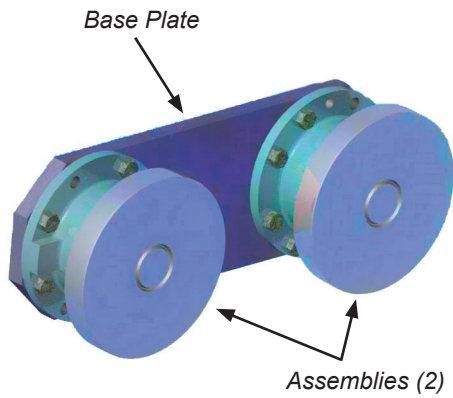

Two Edge Roller Assemblies mounted to a Base Plate.

Item #	Description	RexCon® Part No.
Edge Roller Assemblies		
	1.75" Edge Roller Assembly	612-05274-02
	3" Edge Roller Assembly	602-11213-01
	Base Plate	102-02986-01

Edge Roller Components		
1	Roller	512-06742-80
2	Bearing Cone	298-00186-02
3	Bearing Cup	298-00144-02
4	Housing	412-02505-02
5	Bearing Cup	298-00184-02
6	Bearing Cone	298-00185-02
7	Shim .005"	112-10147-01
	Shim .007"	112-10147-02
	Shim .020"	112-10147-03
8	Retainer Plate	112-08282-01
9	Dust Cover	112-10146-01
10	Snap Ring	298-07510-34



Main Rollers

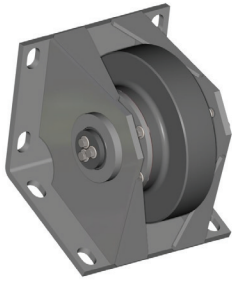

Main Roller Assembly

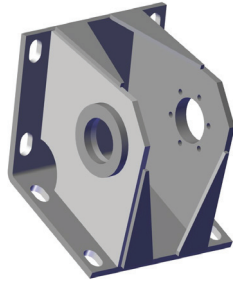

Support for Main Roller

Item #	Description	RexCon® Part No.
Main Roller Assemblies		
	Main Roller Assembly	602-04956-03
	Support for Main Roller	502-05626-80

Main Roller Components		
1	End Plate	102-06236-01
2	Shim .005" Shim .007" Shim .020"	298-10006-02 298-10007-02 298-10008-02
3a, 3b	Gasket End Cap	102-06297-01 502-02129-80
4a, 4b	End Spacer	102-06154-01
5a, 5b	Bearing Cone	298-00195-02
6a, 6b	Bearing Cup	298-00144-02
7	Main Roller	402-01630-04
8	Center Spacer	102-06298-01
9	Shaft	102-02994-01
10	End Plate	102-02993-01

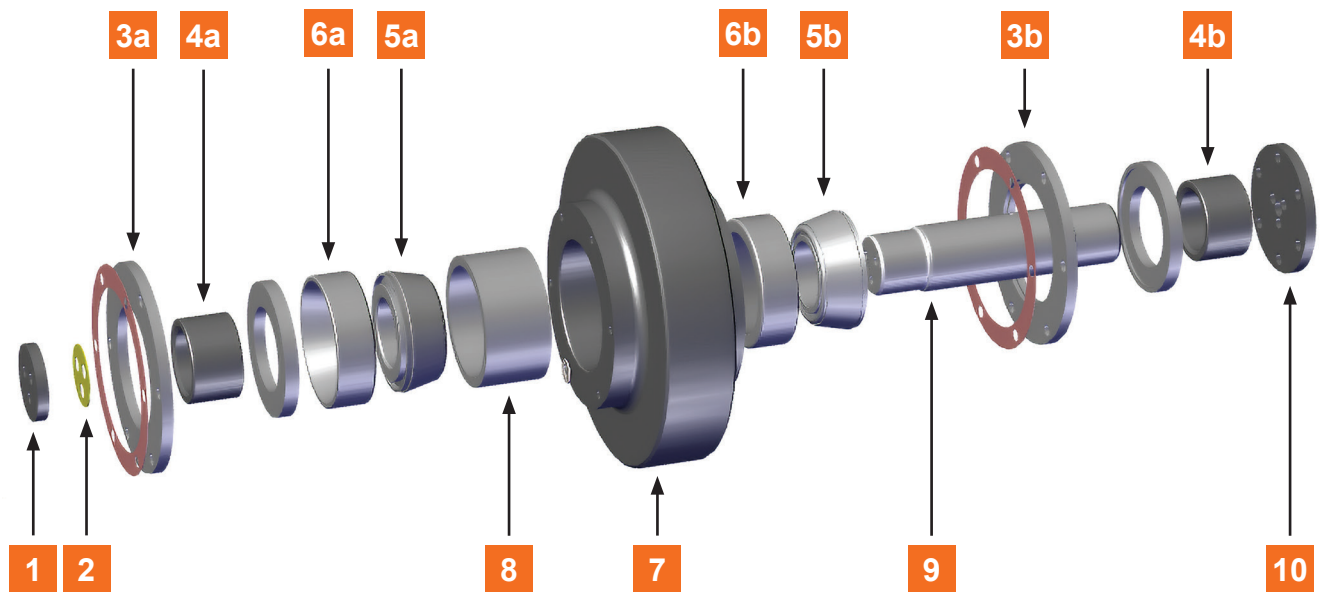

Rollers

TILT MIXERS

Tilt Pin



Item #	Description	RexCon® Part No.
Tilt Pin Assembly Kit		602-04919-06
1	Tilt Pin	102-04287-01
2	Shim	102-06359-02
3	Spacer	102-06358-01
4	Flanged Sleeve	502-03883-80
5	Washer	102-00634-01
6	Special Nut	102-09094-01
7	Shim, 10 ga.	102-02281-01
8	Shim 16 ga.	102-02281-02
9	Shim, 22 ga.	102-02281-03
10	Keeper Plate	102-00631-01
11	Spherical Bearing	298-06802-08

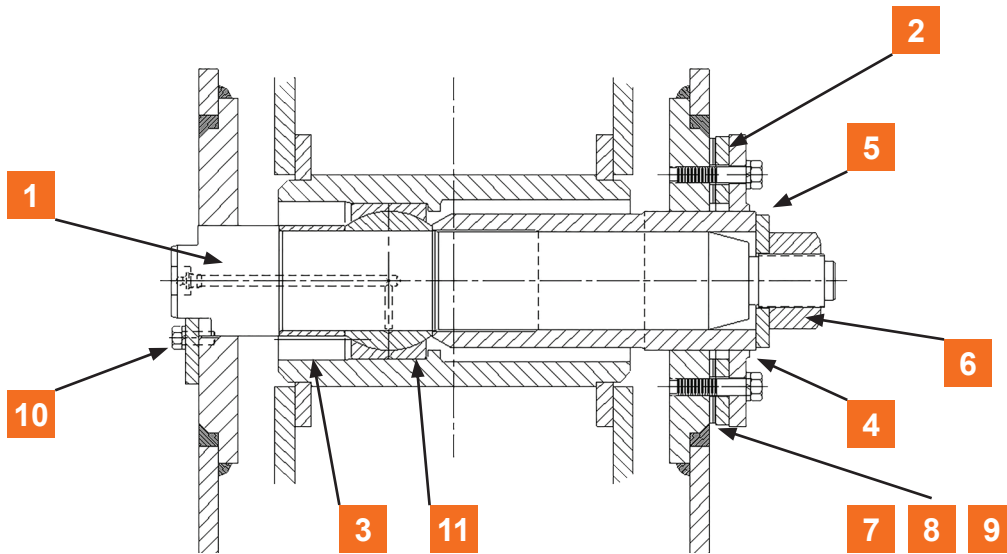

Hydraulic Power Units

Hydraulic Pac



Item #	Description	RexCon® Part No.
	Hydraulic Pac Service Assembly, 30 gpm	114-12224-400
	Hydraulic Pac Assembly, 30 gpm	114-12224-JMG
	Hydraulic Pac Assembly, 45 gpm	114-12225-02
1	Motor, 30 HP	114-12224-13
2	Pump, 33 gpm	114-12224-18
2	Pump, 45 gpm	114-12224-45
3	Filter Head	114-12224-22
4	Filter	112-05125-99
5	Temperature Switch Assembly	114-12224-55
6	Dessicant Breather	114-12224-25
7	Clean Out Gasket, 14"	114-12224-79
7	Clean Out Gasket, 16"	112-05125-91
8	Hub, 1 7/8"	114-12224-14
9	Hub, 1"	114-12224-15
10	Flexible Insert	114-12224-16
11	Proportional Valve	112-05125-56
	Proportional Valve Coil	112-05125-66
12	Emergency Tilt Pump/Motor	114-12224-23
13	Emergency Tilt Valve	114-12224-28
14	Pressure Gauge, 3,000 psi	114-12224-20

TILT MIXERS

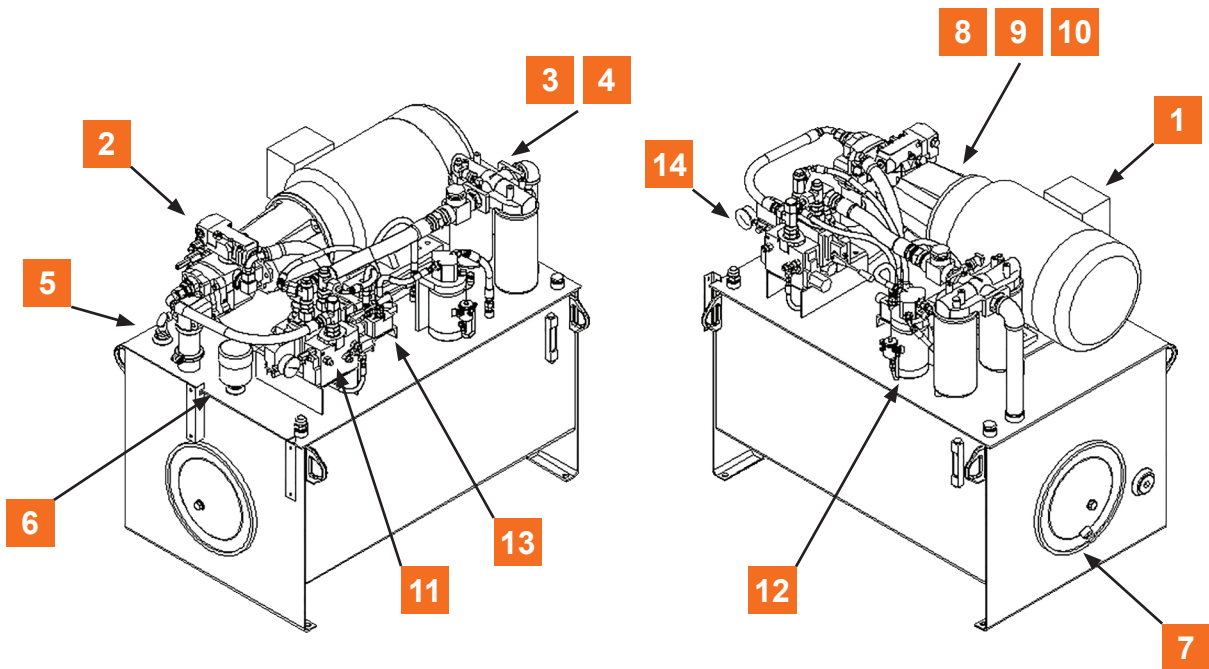

Drive Components

TILT MIXERS

Omega Couplings

Description	RexCon® Part No.	Bore (In)	Bore Out
E30 Size			
E30 Omega Coupling for 60 HP Tilt Drives	112-08418-01	2-3/4"	2-1/8"
E30 Omega Coupling for 50 & 40 HP Tilt Drives	112-08418-02	2-1/8"	2-1/8"
E30 Omega Coupling for 30 HP Tilt Drives	112-08418-03	2-7/8"	2-1/8"
E30 Hub (2-3/8" Bore)	112-08418-05	2-3/8"	
E30 Hub (2-1/8" Bore)	112-08418-06	2-1/8"	
E30 Hub (1-7/8" Bore)	112-08418-07	1-7/8"	
E30 Poly Ring-Syc Part	112-08418-10		

Description	RexCon® Part No.	Bore (In)	Bore Out
E40 Size			
E40 Omega Coupling for 100 & 125 HP Tilt Drives	112-08418-04	2-7/8"	2-1/8"
E40 Hub (2-1/8" Bore)	112-08418-08	2-1/8"	
E40 Hub (2-7/8" Bore)	112-08418-09	2-7/8"	
E40 Poly Ring-Syc Part	112-08418-11		

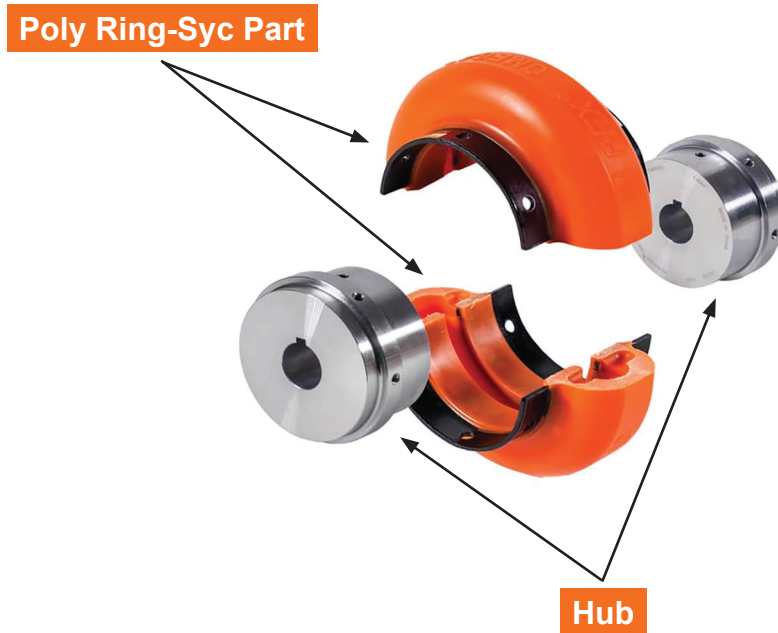

Please refer to the following chart for all drum blade parts.

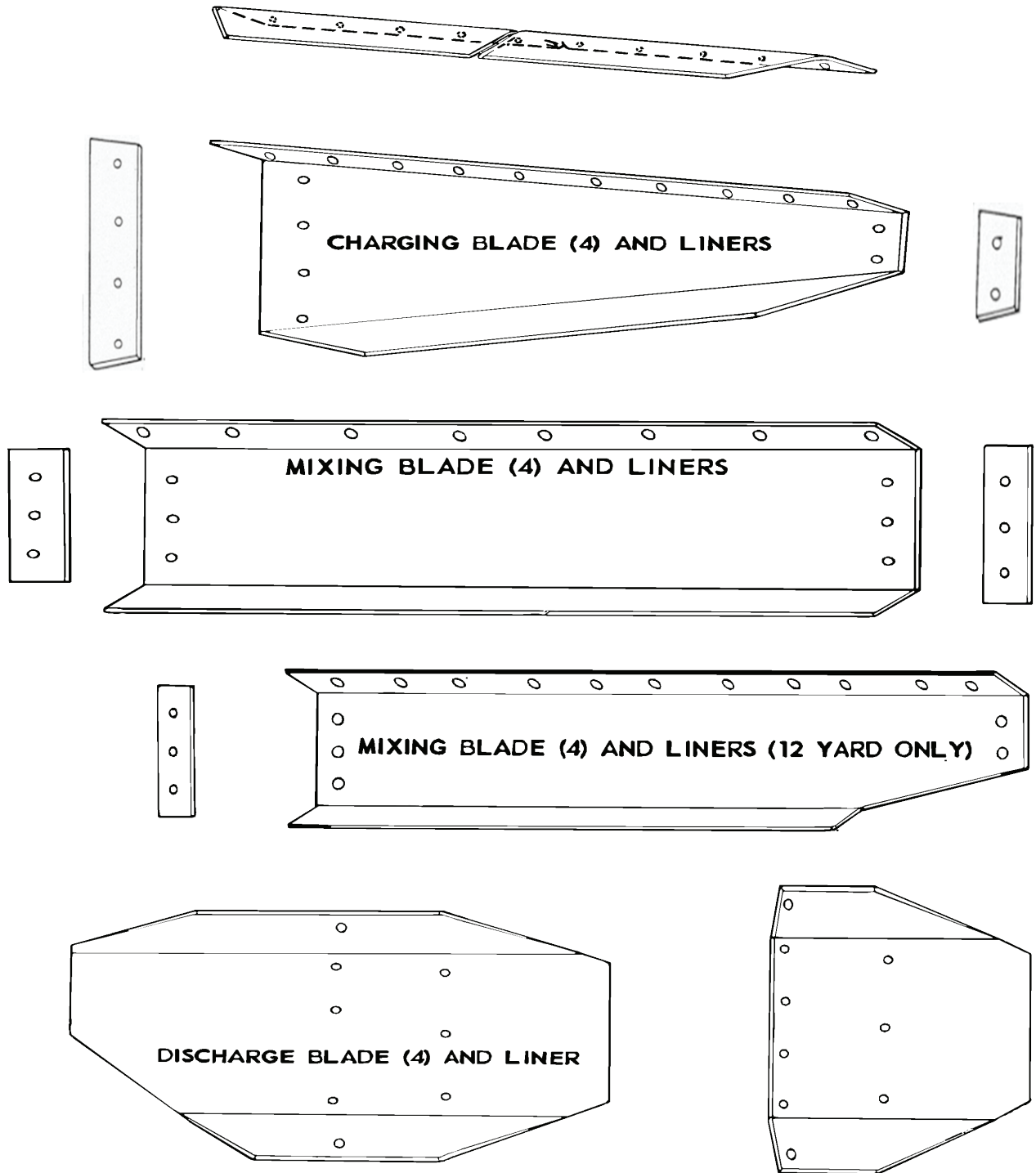

Blades and Blade-Liner Kits

NOTE: Steel liners are only available by special request. Consult with the factory.

Description	No. req'd	RexCon® Part No.
10 Yard Blades (Blade Only)		
10 yd. Blade Kit	1	702-02993-01
Steel Charging Blade	4	502-06240-80
Steel Discharge Blade	4	502-05638-80
Steel Mixing Blade	4	502-05641-80
Steel Capacity Blade	4	502-05962-80
Hardware Kit	1	702-02996-HW

10 Yard Blades with Chromium Liners		
10 yd. Chromium Lined Blade Kit	1	702-02993-CHROME
Charging Blade	4	502-06240-CHROME
Mixing Blade	4	502-05641-CHROME
Discharge Blade	4	502-05638-CHROME
Capacity Blade	4	502-05962-CHROME
Hardware Kit	1	702-02996-HW

10 Yard Chromium Liners Only		
10 yd. Chromium Liners Only	1	702-03397-CHROME

Description	No. req'd	RexCon® Part No.
12 Yard Blades (Blade Only)		
12 yd. Blade Kit	1	702-02996-01
Steel Charging Blade	4	502-06240-80
Steel Discharge Blade	4	502-05638-80
55° Steel Center Mixing Blade	2	502-06259-80
30° Steel Center Mixing Blade	2	502-06261-80
Steel Capacity Blade	4	502-05962-80
Hardware Kit	1	702-02996-HW

12 Yard Blades with Chromium Liners		
12 yd. Chromium Lined Blade Kit	1	60300203
Charging Blade	4	502-06240-CHROME
Discharge Blade	4	502-05638-CHROME
55° Center Mixing Blade	2	502-06259-CHROME
30° Center Mixing Blade	2	502-06261-CHROME
Capacity Blade	4	502-05962-CHROME
Hardware Kit	1	702-02996-HW

12 Yard Chromium Liners Only		
12 yd. Chromium Liners Only	1	702-03654-CHROME

High Speed Blades

12 Yard High Speed Blade Kit

Includes center mix blades only. Purchase charge, discharge, and capacity blades separately which can be lined with steel or wrap-around poly liners.

12 L High Speed Blade Kit

Includes center mix blades only. Purchase charge, discharge, and capacity blades separately which can be lined with steel or wrap-around poly liners.

Description	RexCon® Part No.
12 yd. High Speed Blade Kit	702-02998-01
Hardware Kit: Includes hardware for all blades.	702-02998-01HW

Description	RexCon® Part No.
12 L High Speed Blade Kit	702-02999-01
Hardware Kit: Includes hardware for all blades.	702-02999-01HW

Description	No. required	RexCon® Part No.
12 Yard High Speed Blades		
Charging Blade	4	502-06240-XXX
Discharge Blade	4	502-05638-XXX
Outer Spiral Charge Blade	4	512-07083-81
Inner Spiral Charge Blade	4	512-06987-82
Inner Spiral Discharge Blade	4	512-06987-81
Outer Spiral Discharge Blade	4	512-06987-80
Capacity Blade	4	502-05962-XXX

Description	No. required	RexCon® Part No.
12 L High Speed Blades		
Charging Blade	4	502-06240-XXX
Discharge Blade	4	502-05638-XXX
Outer Spiral Charge Blade	4	512-07083-80
Inner Spiral Charge Blade	4	512-06987-82
Inner Spiral Discharge Blade	4	544-11769-80
Outer Spiral Discharge Blade	4	544-11768-80
Capacity Blade	4	502-05962-XXX

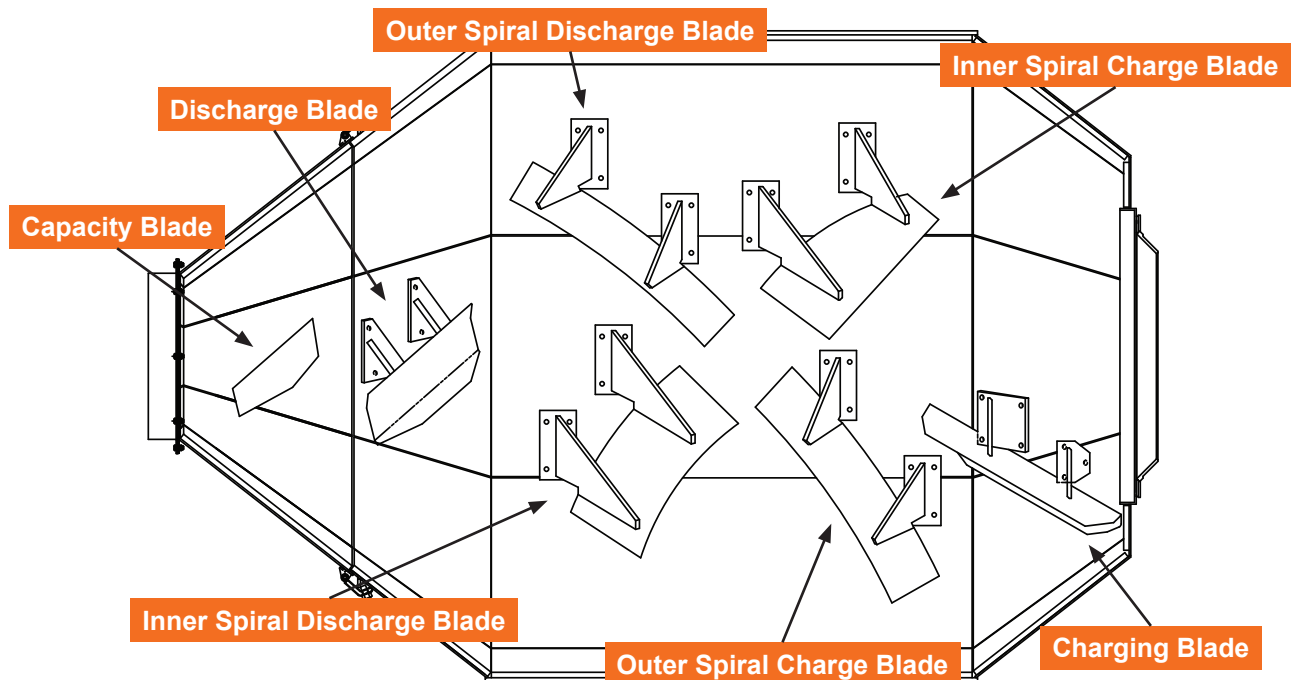

Consumables

Polyurethane Blade Liners

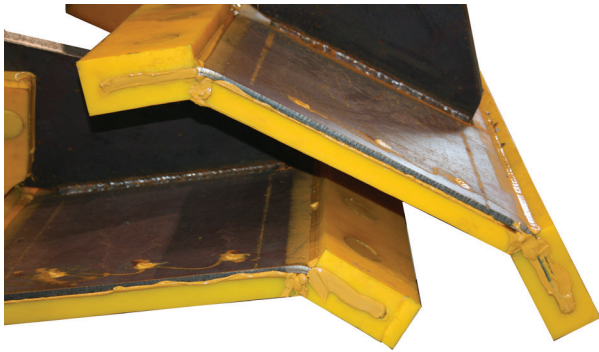

Description	No. req'd	RexCon® Part No.
10 Yard Blades with Wrap-Around Poly Liners		
10 yd. Blade Kit with Wrap-Around Poly Liners	1	60300205
10 yd. Wrap-Around Liners Only	1	702-03397-WRAP
Charging Blade	4	502-06240-WRAP
Mixing Blade	4	502-05641-WRAP
Discharge Blade	4	502-05638-WRAP
Capacity Blade	4	502-05962-POLYB
Hardware Kit	1	702-02996-HW

12 Yard Blades with Wrap-Around Poly Liners		
12 yd. Blade Kit with Wrap-Around Poly Liners	1	702-02996-WRAP
12 yd. Wrap-Around Liners Only	1	102-13027-WR01
Charging Blade	4	502-06240-WRAP
Discharge Blade	4	502-05638-WRAP
55° Mixing Blade	2	502-06259-WRAP
30° Mixing Blade	2	502-06261-WRAP
Capacity Blade	4	502-05962-POLYB
Hardware Kit	1	702-02996-HW

Rex Tilt Mixer Poly Liners

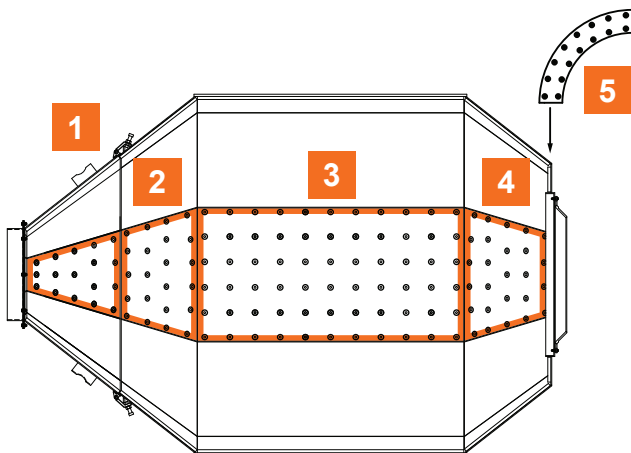

1	Nose Cone Liner
2	Discharge Cone Liner
3	Belly Liner
4	Charge Cone Liner
5	End Ring Liner

Description	No. req'd	RexCon® Part No.
10 Yard Rex Tilt Mixer Poly Liners		
10 yd. Poly Drum Liner Kit	1	702-03393-01T
Poly Belly Liner	8	102-31448-01
Poly End Ring	4	102-31433-01
Poly Charge Cone	8	102-31434-01
Poly Discharge (Nose) Cone Ext.	8	102-31436-01
Poly Discharge Cone	8	102-31437-01

12 Yard Rex Tilt Mixer Poly Liners		
12 yd. Poly Drum Liner Kit	1	702-03395-01T
Poly Belly Liner	8	102-31435-01
Poly End Ring	4	102-31433-01
Poly Charge Cone	8	102-31434-01
Poly Discharge (Nose) Cone Ext.	8	102-31436-01
Poly Discharge Cone	8	102-31437-01
Plugs Only		102-12035-01

Plant Component Liners

We can cut and supply the proper fitting liners for any plant component that requires wear protection from batch material.

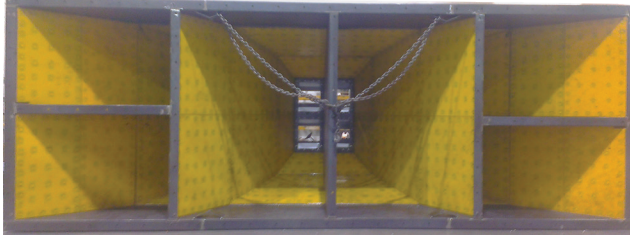

CFI - Contact for Information

Various types of liners available for different wear resistant applications; consult with the factory for specific pricing and availability.

Please contact your RexCon[®] Distributor for further details.

Water Meters

Turbo Meters

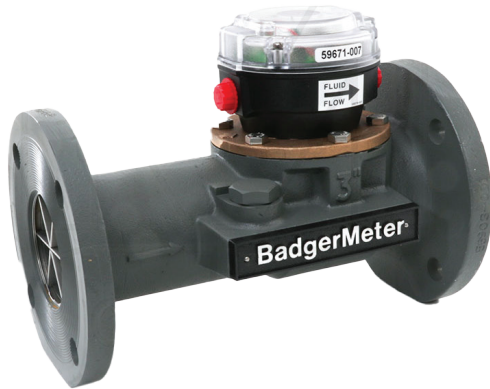

Description	RexCon® Part No.
2" Turbo Water Meter	
2" Badger Turbo Meter	298-02178-56
Rotor & Spindle	112-10114-70
Head Tetraseal	112-10114-39
Head Gasket	112-10114-52
3" Turbo Water Meter	
3" Badger Turbo Meter	298-02177-56
Rotor & Spindle	112-10114-71
Pulse Transmitter	212-02112-56
Head Tetraseal	112-10114-39
Head Gasket	112-10114-52
Straightening Vane	112-10114-28
PFT4E Board	298-00231-00
Badger Turbo Meter Head	112-10114-22

Mag Meters



Description	RexCon® Part No.
3" Mag Meter	212-11096-53
2" Mag Meter	298-02178-56
Board Only	212-11096-53-11

Water Pumps

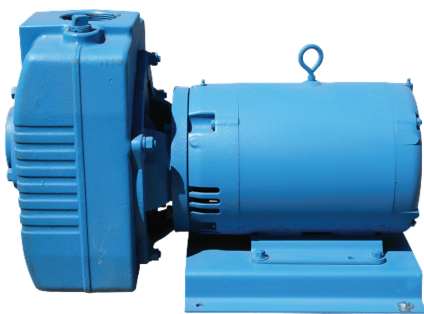

Description	RexCon® Part No.
3" 15 HP Assembly	612-05134-01
Pump	212-00037-56
Drive Coupling	212-08239-91
Motor: 15 HP	212-00141-20
Power Flow Water Pump	212-02167-56

Auto Lube System



Description	RexCon® Part No.
Tilt Mixer Auto Lube System	644-14318-03
Auto Lube Repair Kit	114-14243-400
Pump with Reservoir	114-14243-90
Pump Element	41060111

Call our parts department for individual grease system parts: 262-539-4050.

Drip Oiler



Description	RexCon® Part No.
Drip Oiler Assembly	644-14944-01
Drip Oiler	212-11164-53
Coil	212-11164-53-01
Sight Glass Assembly	212-1116453-02
5 Gal Grease Bucket	212-00016-44

Ring Gear Self Lubricator



Description	RexCon® Part No.
Ring Gear Self Lubricating Kit	644-15758-400
Pump with Hoses	114-15757-01
Timer	60-66541-01
Grease Manifold	524-15759-80

Central Lube Systems

Description	RexCon® Part No.
Base Trailer Central Lube System	644-14340-01
Horizontal Mixer Central Lube	644-14314-03

Load Cells

S-Type (Hanging)



Description	RexCon® Part No.
1,500 lb.	298-00233-17
2,000 lb.	298-00234-17
2,500 lb.	298-00235-17
3,000 lb.	298-00236-17
5,000 lb.	298-00237-17
10,000 lb.	298-00238-17
15,000 lb.	298-00239-17
20,000 lb.	298-00240-17

Compression Type

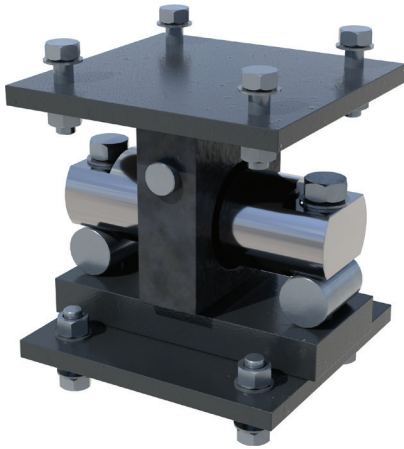

Description	RexCon® Part No.
5,000 lb. compression	212-26152-17
10,000 lb. compression with mount	212-26141-18
20,000 lb. compression with mount	212-26142-18

WEIGH SYSTEMS

Tilt Speed Control



Description	RexCon® Part No.
Tilt Speed Control Assembly (Table Top)	60-66489-01
Tilt Speed Control Board	20-14083-17
Potentiometer	298-16019-17
Knob, Potentiometer	298-00115-17
Power Supply	20-23096-17
Lens, Green	298-12035-17
Light Socket	298-12033-17
LED Bulb, White	298-12041-17

Mixer Junction Box



Mixer Junction Box

Description	RexCon® Part No.
Mixer Junction Box	60-66304-01
Emergency Stop Button	298-06152-17
Emergency Stop Contact Block	298-06013-17
Horn	298-00138-17
Horn Gasket	20-00516-17

Mixer Junction Box (2020 and later)	
Description	RexCon® Part No.
Mixer Junction Box	60-66570-01
Emergency Stop Button	298-07137-17
Emergency Stop Contact Block	298-07131-02
Horn with Gasket	298-00538-17

Relays



Description	RexCon® Part No.
Black Opt Relay	20-14058-17
Yellow Opt Relay	20-15125-17
Fuse, 3 amp (for use with Black Opt Relay and Yellow Opt Relay)	20-11092-17
Relay, 120V AC with Socket Phoenix Contact	20-14112-17
Relay, 24V DC with Socket Phoenix Contact	20-14113-17
Relay, 24V DC Coil with Socket Mech Form C	20-14119-17
Timing Relay, Multimode 1, Form C	20-20593-17

Buttons



Push Button Operator

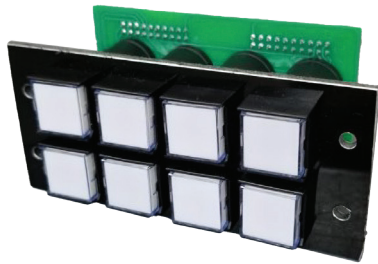

LED Push Button Assembly, current style

Description	RexCon® Part No.
Push Button Operator	298-06030-17
LED Push Button Assembly (8 buttons, current style)	20-15149
LED Push Button Assembly (8 buttons, old style)	60-66273-01
Push Button Caps	20-06414-17
Push Button Amber Lamps	20-12156-17
Push Button Red Lamps	20-12163-17

Switches

Switches

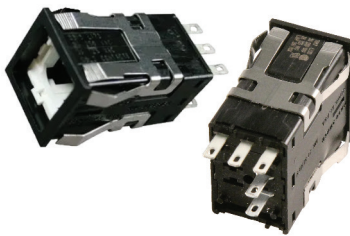

Push Button Switch



Float Switch

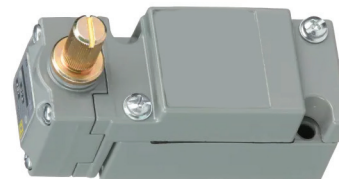

Limit Switch

Description	RexCon® Part No.
Push Button 1-Pole Momentary	298-06223-17
Push Button 2-Pole Momentary	298-06198-17
Push Button 2-Pole Maintain	298-06199-17
Float Switch	212-00105-17
Limit Switch Arm	212-00029-17
Limit Switch	298-06568-17

Contact Blocks



Description	RexCon® Part No.
1 normally open, 1 normally closed	298-06021-17
1 normally open	298-06012-17
2 normally open	298-06004-17
1 normally closed	298-06013-17
2 normally closed	298-06051-17

Indicators



Showing 4 each of Plates, Sockets, Bulbs, and Lenses



LCD Water Counter

Description	RexCon® Part No.
Legend Plate	102-11437-01
Light Holder/Socket	298-12033-17
Bulbs	298-12041-17
Red Lens	298-12034-17
Clear Lens	298-12036-17
Warning Light for Decumulative Bin (consult factory for complete system)	60-66464-01
LCD Water Counter (2 batteries required, see battery part 298-03262-17 below)	298-20566-17
Battery for LCD Counter (1 battery)	298-03262-17
LCD Water Counter with built-in, non-replaceable batteries	298-20568-17

Miscellaneous

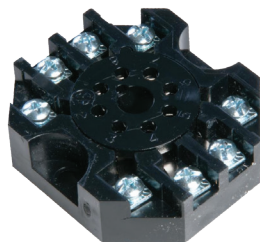

Socket-Octal-8-Term

Description	RexCon® Part No.
Cords	OIR*
Socket-Octal-8-Term	298-13214-17
Relay DPDT 115V 60 CY (for use with Socket-Octal-8-Term)	298-15004-17
Timer, 110V AC Plug in 0-10 Hrs (for use with Socket-Octal-8-Term)	20-20586

OIR - Ordering Information Required

Cords are manufactured by motor horsepower rating, number of connector pins, and cord length. We can supply custom cords for your individual plant needs.

BOOTS

GUM RUBBER.....	1
PRE-CUT LENGTHS.....	1
BULK SIZES	2

PNEUMATICS

CYLINDERS.....	4
AIR CYLINDERS	4
HYDRAULIC CYLINDERS	4
PINS	5
AIR TREATMENT	5
AIR VALVES.....	5
AIR & HYDRAULIC VALVES	6

DUST COLLECTION

REPLACEMENT FILTERS	7
BAGS (FOR RA AND BP UNITS).....	7
CARTRIDGES (FOR CP UNITS).....	7
RETURN BLOWERS & PARTS	7
COUPLINGS	8
ELECTRICAL TIMERS	8
BUTTERFLY VALVES & PARTS.....	8
SOLENOID VALVES	9

GATE VALVES & ACTUATORS

GATES	11
AGGREGATE BIN CLAMSHELL GATES	11
GATE ACCESSORIES	11
ASSEMBLIES	12
CONVERSION KITS	12
BUTTERFLY & ACTUATOR	13
CRANE® CENTER LINE	13
KEYSTONE®.....	13
BRAY®	13

BIN COMPONENTS

BIN COMPONENTS	15
BIN LEVEL INDICATORS.....	15
VIBRATORS.....	15

SILO COMPONENTS

SILO AERATION	17
AERATION COMPONENTS.....	17
BLOWERS & VALVES.....	17

Table of Contents

TABLE OF CONTENTS

AGGREGATE CONVEYORS

IDLERS.....	19
TROUGHING & RETURN IDLERS	19
PULLEYS.....	19
CONVEYOR BELT WIPERS.....	19
NEW SPRING LOADED WIPERS	19
CONVEYOR ACCESSORIES.....	20

POWER TRANSMISSION

POWER TRANSMISSION	21
MIXER DRIVE ASSEMBLIES.....	21
TEFC DRIVE PARTS.....	21
TEFC DRIVE ASSEMBLIES.....	21
DOUBLE REDUCTION	22
INPUT ASSEMBLY	22
OUTPUT ASSEMBLY	22
REDUCERS/DRIVERS	23
STANDARD DRIVE MOTORS	23

TILT MIXERS

CHARGE & DISCHARGE CONES.....	25
DETACHABLE DISCHARGE CONE	25
DETACHABLE CONE LATCH KIT.....	25
STANDARD DRUM ASSEMBLY.....	26
POLY CHARGE CONE ADAPTER.....	27
CHARGE CHUTES	27
ROLLERS.....	28
EDGE ROLLERS.....	28
MAIN ROLLERS	29
TILT PIN	30
HYDRAULIC POWER UNITS.....	31
HYDRAULIC PAC	31
DRIVE COMPONENTS.....	32
OMEGA COUPLINGS	32
CONSUMABLES	33
BLADES AND BLADE-LINER KITS.....	34
HIGH SPEED BLADES	35
POLYURETHANE BLADE LINERS	36
REX TILT MIXER POLY LINERS	36
PLANT COMPONENT LINERS	37

Table of Contents

WATER SYSTEMS

WATER METERS.....	39
TURBO METERS	39
MAG METERS.....	39
WATER PUMPS.....	39

LUBRICATION SYSTEMS

AUTO LUBE SYSTEMS	41
AUTO LUBE SYSTEM.....	41
DRIP OILER.....	41
RING GEAR SELF LUBRICATOR	41
CENTRAL LUBE SYSTEMS.....	41

WEIGH SYSTEMS

LOAD CELLS.....	43
S-TYPE (HANGING)	43
COMPRESSION TYPE.....	43

ELECTRICAL

JUNCTION BOXES.....	45
TILT SPEED CONTROL	45
MIXER JUNCTION BOX.....	45
RELAYS	45
BUTTONS.....	46
SWITCHES.....	46
SWITCHES	46
CONTACT BLOCKS	47
INDICATORS.....	47
MISCELLANEOUS	47

TABLE OF CONTENTS



ASTEC[®]

www.astecindustries.com